



Pneumatic Riveter

R1A2



MADE IN JAPAN tradition

Pneumatic Riveter

R1A2

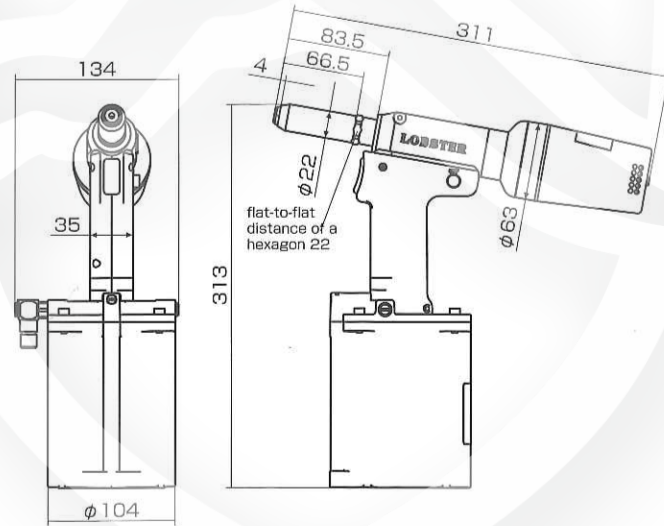

Model	Weight kg (lbs)	Compatible Rivets φmm (inch)	Jaw	Used air pressure MPa (kgf/cm ²)	Traction Power kN (lb.f)	Stroke mm (inch)	Air Consumption L/min	Noise Emission dB
R1A2	1.74 (3.84)	all material 4.8 / 6.4 (3/16", 1/4")	Ultra Jaw 'L'	0.49~0.59 (5~6)	18.5 (4,158)*	26 (1.02")	75* (Vacuum on)	80

*Air pressure at 0.59 Mpa

⚠ Caution for secure usage Be sure to read the enclosed Instruction Manual carefully and make sure that you understand them thoroughly before using this tool.

- All dimensions are nominal and subject to tolerances.
- Specifications are subject to change without prior notice.

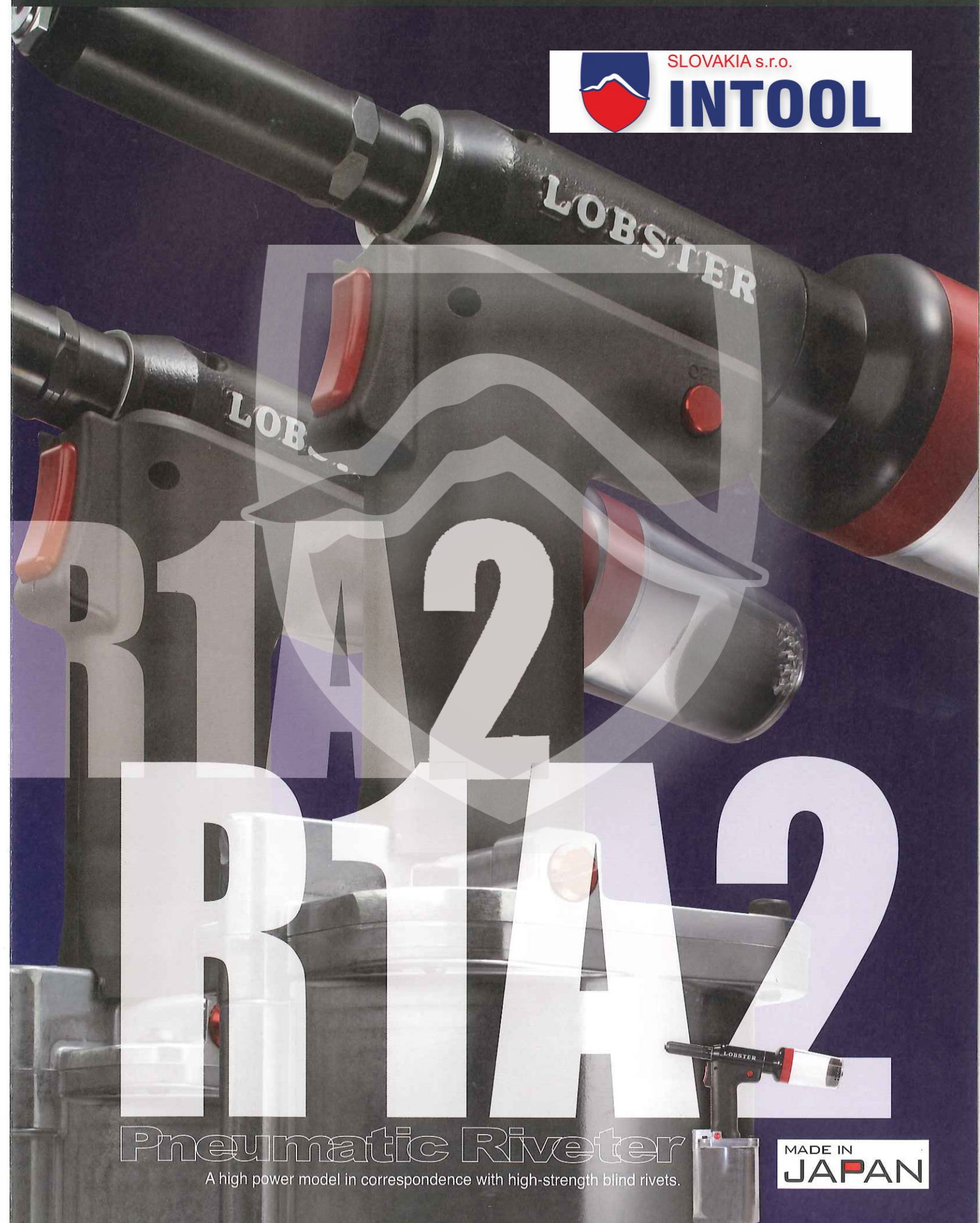

Pneumatic Riveter

A high power model in correspondence with high-strength blind rivets.

MADE IN JAPAN



INTOOL SLOVAKIA, s.r.o., Národná 814/4, 010 01 Žilina, tel: +421 904 001 920
www.intool.sk



Lightweight · Heavy duty · Long stroke

	NEW R1A2
Rivet sizes	4.8mm, 6.4mm (3/16", 1/4")
Stroke	26mm (1.02")
Traction Power	18.5kN (4,158 lb.f)※

※based on operating air pressure of 0.59MPa(85psi)

A heavy duty riveter capable of setting structural rivets.



Pneumatic Riveter

Narrow Frame Head

22.0mm(.866") diameter Frame Head allows for use in tight spaces.



The resin grip which makes it easy to grip

Well balanced tool with a comfortable feel in the operator's hand. Handle has a natural curve that is easy to grip.



Air intake with changeable left/right direction

Air inlets on both the left and right side allowing for greater flexibility, and operator productivity.



Reduced air consumption of approx. 30% compared with our conventional model

With an improved air circuitry design, consumes 30% less air than previous generation tools. This reduces compressor costs and is environmentally friendly.



Oversized mandrel container

Oversized mandrel container. Improved efficiency = greater productivity



Long Stroke

R1A2 26mm(1.02")



On-board vacuum on/off switch

Conveniently located on/off button controls vacuum mandrel collection. Simply push the button to activate vacuum, then switch to off when not in use to reduce air consumption and cost.

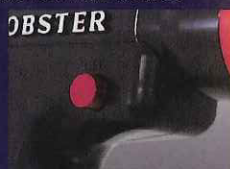

Lightweight, durable design

As ergonomic leaders, Lobster designed a lightweight riveter durable enough for use in high volume applications. A superb center-balance design is comfortable in the operators hand, enhancing the lightweight feel.

R1A2

NEW R1A2

Lobster Tools riveters are heavy duty production tools made in Japan and used worldwide. MADE IN JAPAN spirit is embodied in R1A2 to high acclaim and have achieved the prestigious Good Design award for 2012.



Lobster has been manufacturing products in Japan for over 120 years. The Made in Japan tradition has a history of providing high quality products to our customers.